

Engineering Department
Manual Of
Practice



Life. Well Crafted.

100 Erosion/Sedimentation Control

NOT TO SCALE



CITY OF HICKORY
GENERAL NOTES FOR
EROSION/SEDIMENTATION CONTROL

DATE:
2-1-07

SHEET 1 OF 1
STD. NO.
101

NOTE: POSTS SHALL BE SPACED AT A MAXIMUM OF 8' IF FENCE IS SUPPORTED WITH WIRE, AND A MAXIMUM OF 6' IF FENCES USES EXTRA STRENGTH FABRIC WITHOUT SUPPORT WIRE.

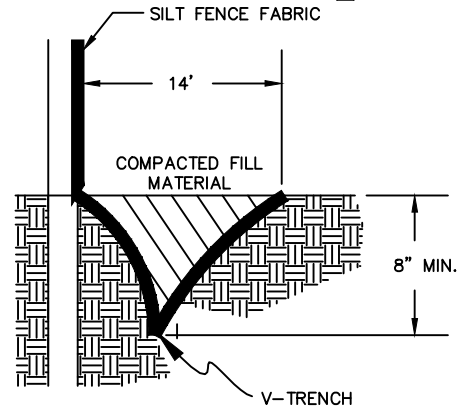
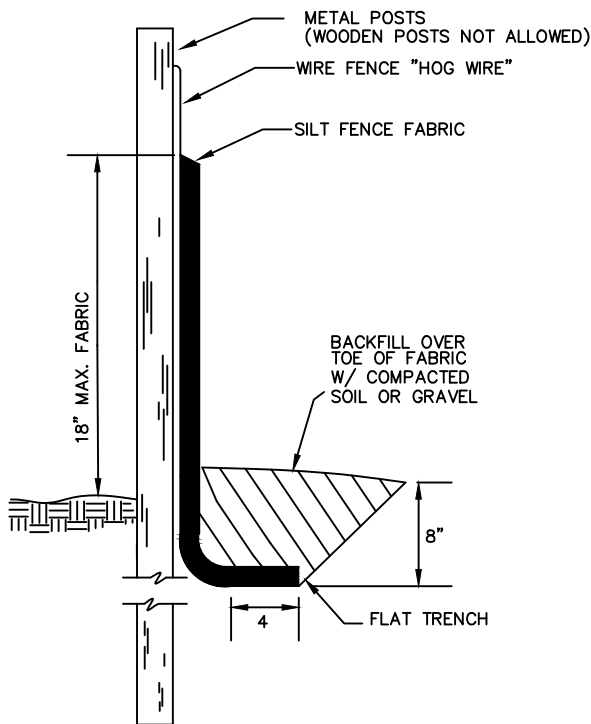
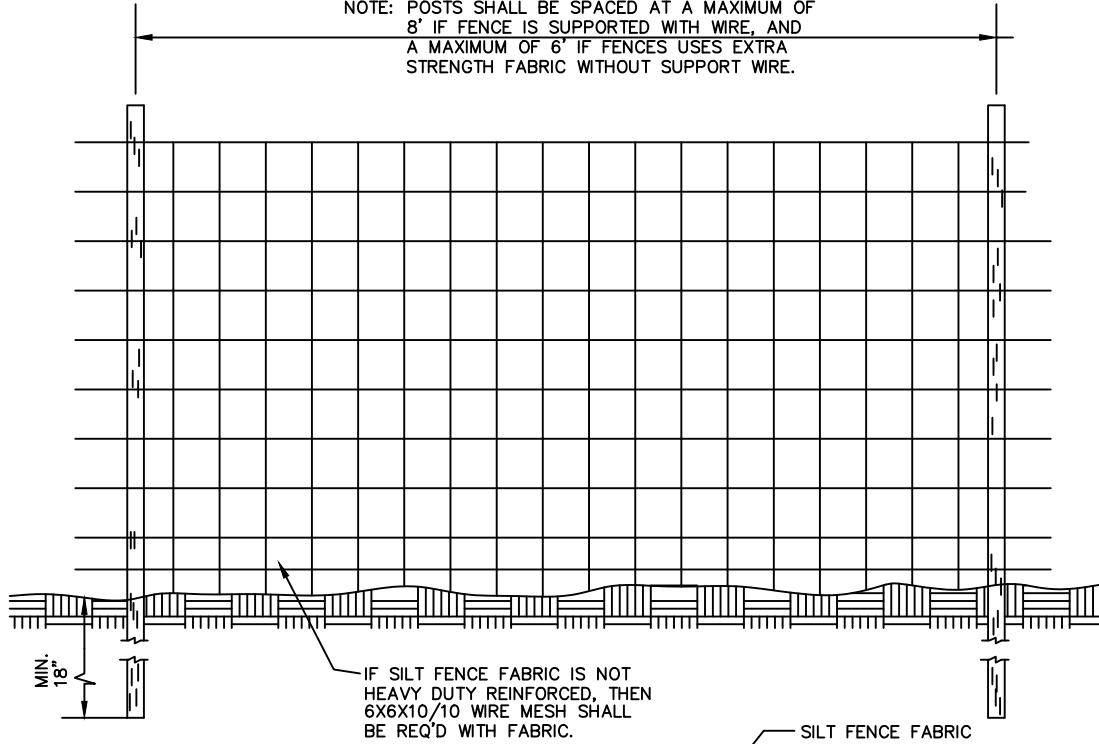

ALTERNATE TRENCHING DETAIL

GENERAL NOTES

- 1) FENCE FABRIC SHALL BE A MINIMUM OF 32" IN WIDTH AND SHALL HAVE A MINIMUM OF 6 LINE WIRES WITH 12" STAY SPACING.
- 2) SILT FENCE FABRIC SHALL BE SYNTHETIC OR OTHER APPROVED MATERIAL MEETING AN 85% MIN. FILTERING EFFICIENCY AND MIN. 30 LB./ LIN IN TENSILE STRENGTH WITH A MIN 6 MONTH EXPECTED USEABLE CONSTRUCTION LIFE. INSTALL FABRIC IN ACCORDANCE WITH MANUFACTURER'S INSTRUCTIONS.
- 3) STEEL POST SHALL BE THE SELF-FASTENER ANGLE STEEL TYPE.
- 4) BACKFILL OVERTOP OF FABRIC SHALL BE COMPACTED TO A MINIMUM OF 95% MODIFIED PROCTOR

NOT TO SCALE



CITY OF HICKORY

TEMPORARY SILT FENCE

DATE:
2-1-07

SHEET 1 OF 1
STD. NO.
102

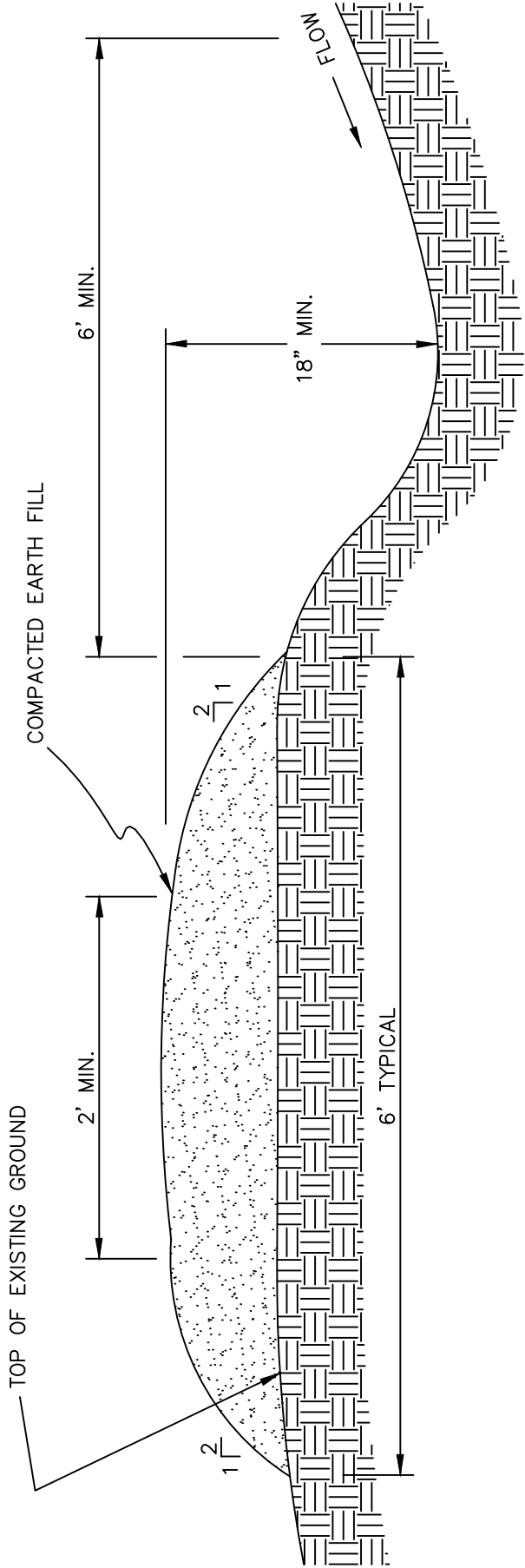

NOT TO SCALE



CITY OF HICKORY

TEMPORARY DIVERSION
CROSS-SECTION

SHEET 1 OF 1	
DATE: 2-1-07	STD. NO. 103

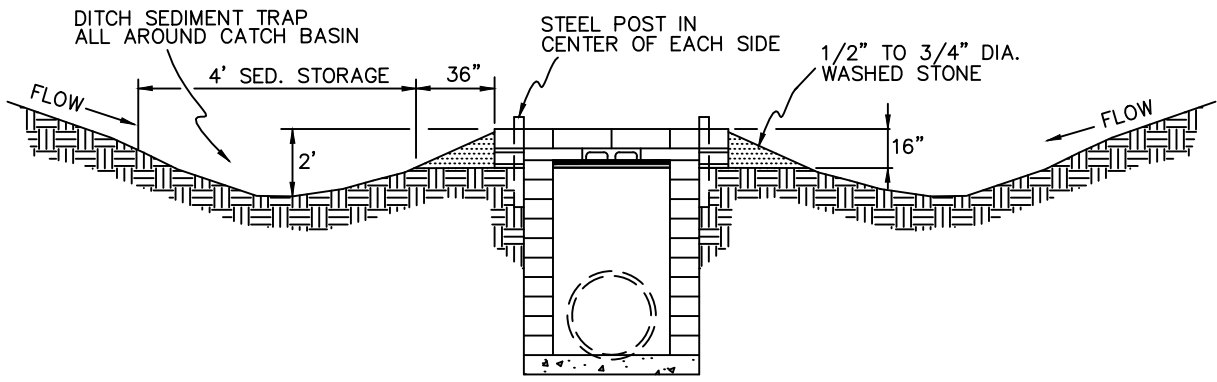
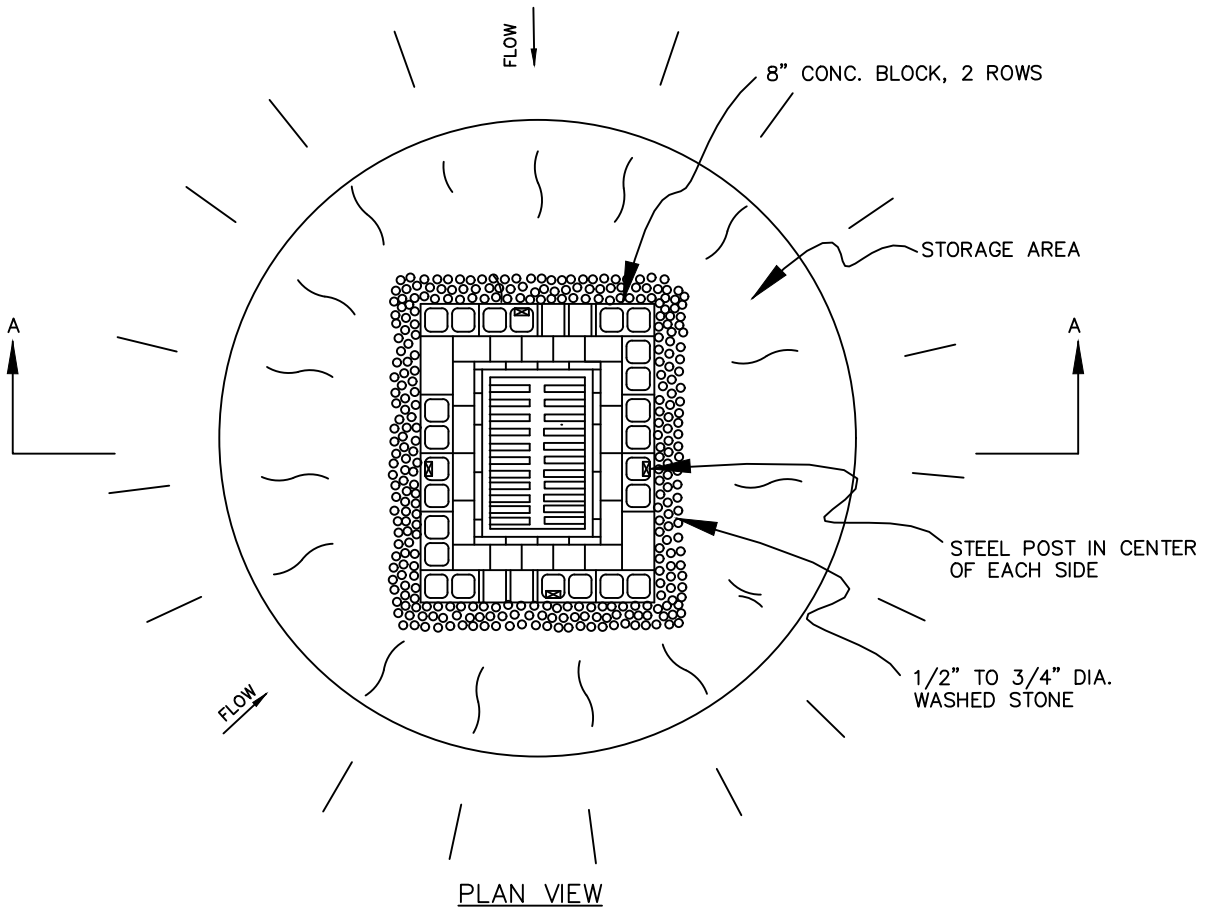

GENERAL NOTES:

SEDIMENT SHALL BE REMOVED AND TRAP RESTORED TO ITS ORIGINAL DIMENSIONS WHEN THE SEDIMENT HAS ACCUMULATED TO 1/2 THE DESIGN DEPTH OF THE TRAP. REMOVED SEDIMENT SHALL BE DEPOSITED IN A SUITABLE AREA AND IN SUCH A MANNER THAT IT WILL NOT ERODE.

THE STRUCTURE SHALL BE INSPECTED AFTER EACH RAIN AND REPAIRS MADE AS NEEDED.

CONSTRUCTION OPERATIONS SHALL BE CARRIED OUT IN SUCH A MANNER THAT EROSION AND WATER POLLUTION SHALL BE MINIMIZED.

THE SEDIMENT TRAP SHALL BE REMOVED AND THE AREA STABILIZED WHEN THE REMAINING DRAINAGE AREA HAS BEEN PROPERLY STABILIZED.

NOT TO SCALE



CITY OF HICKORY

BLOCK & GRAVEL
DROP INLET PROTECTION

SHEET 1 OF 1

DATE:
2-1-07

STD. NO.
104

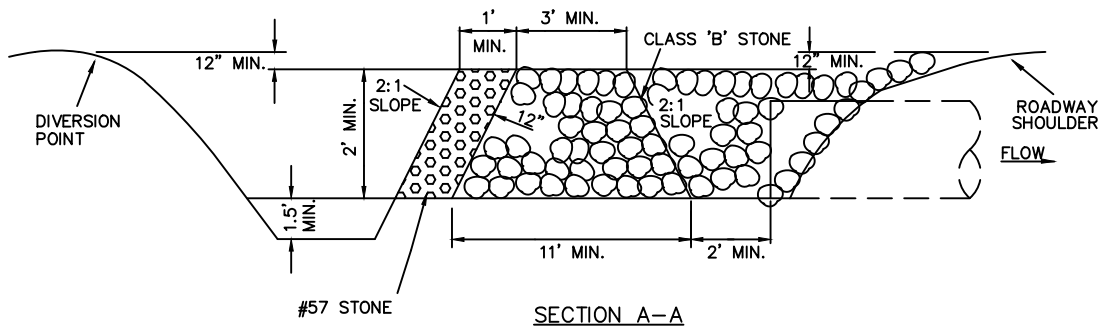
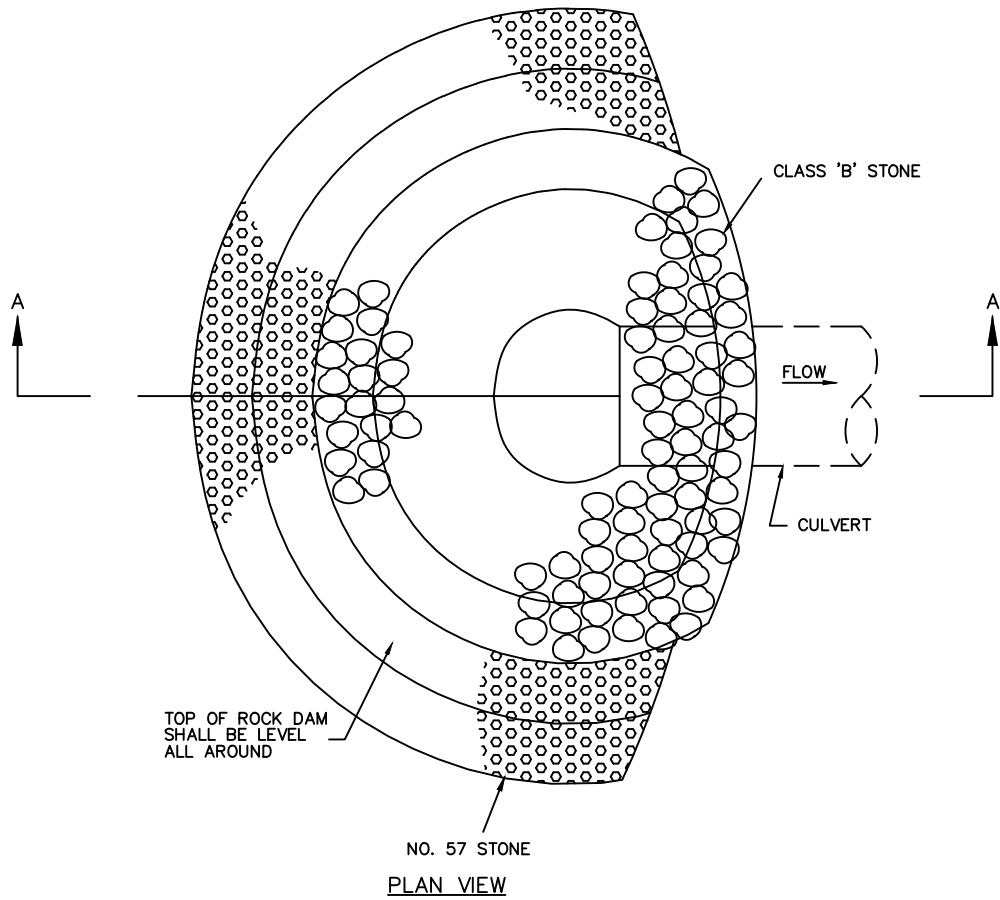

NOT TO SCALE



CITY OF HICKORY

ROCK PIPE INLET
SEDIMENT TRAP

SHEET 1 OF 1

DATE:
2-1-07

STD. NO.
105

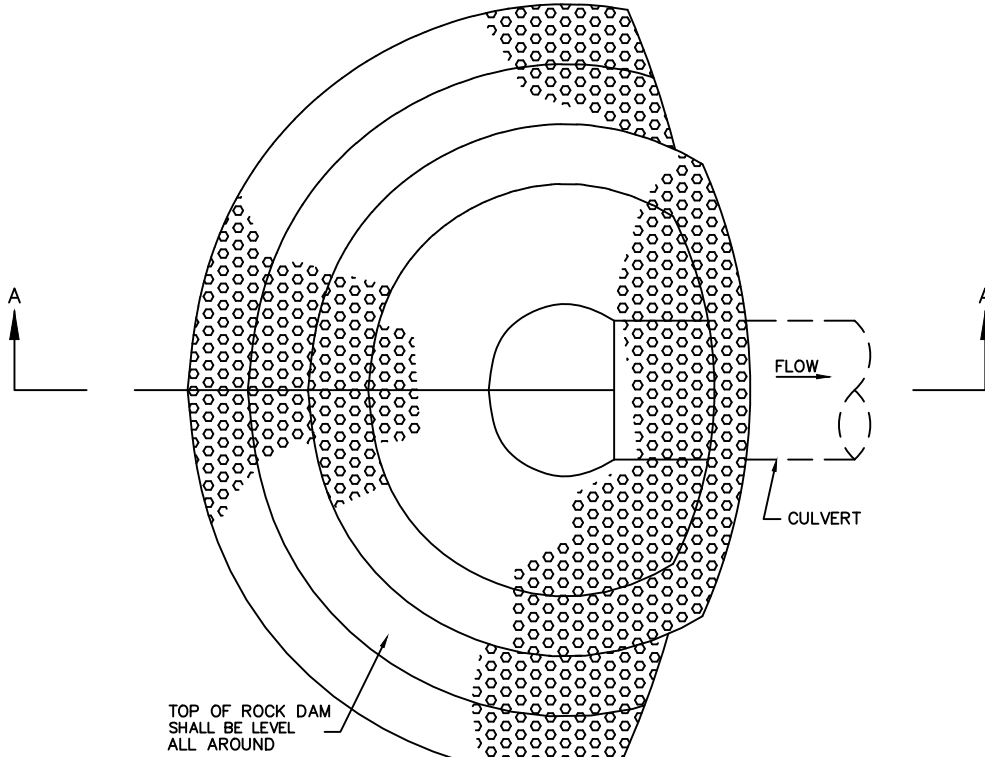

57 STONE
PLAN VIEW

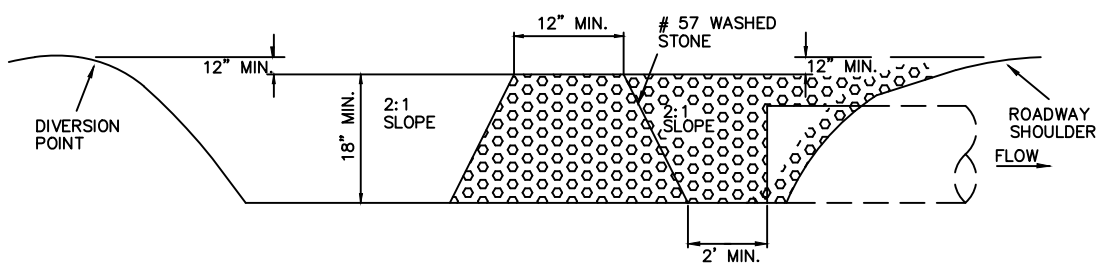

SECTION A-A

NOT TO SCALE



CITY OF HICKORY

MODIFIED SMALL DRAINAGE AREA
ROCK PIPE INLET
SEDIMENT TRAP

SHEET 1 OF 1
DATE: 2-1-07
STD. NO. 106

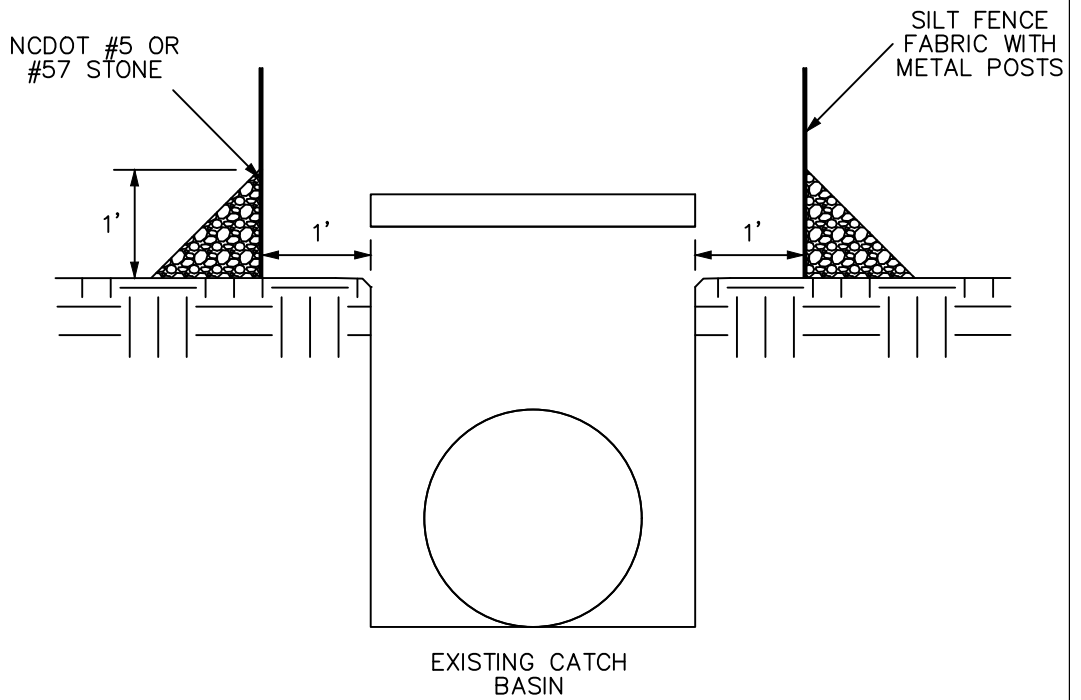
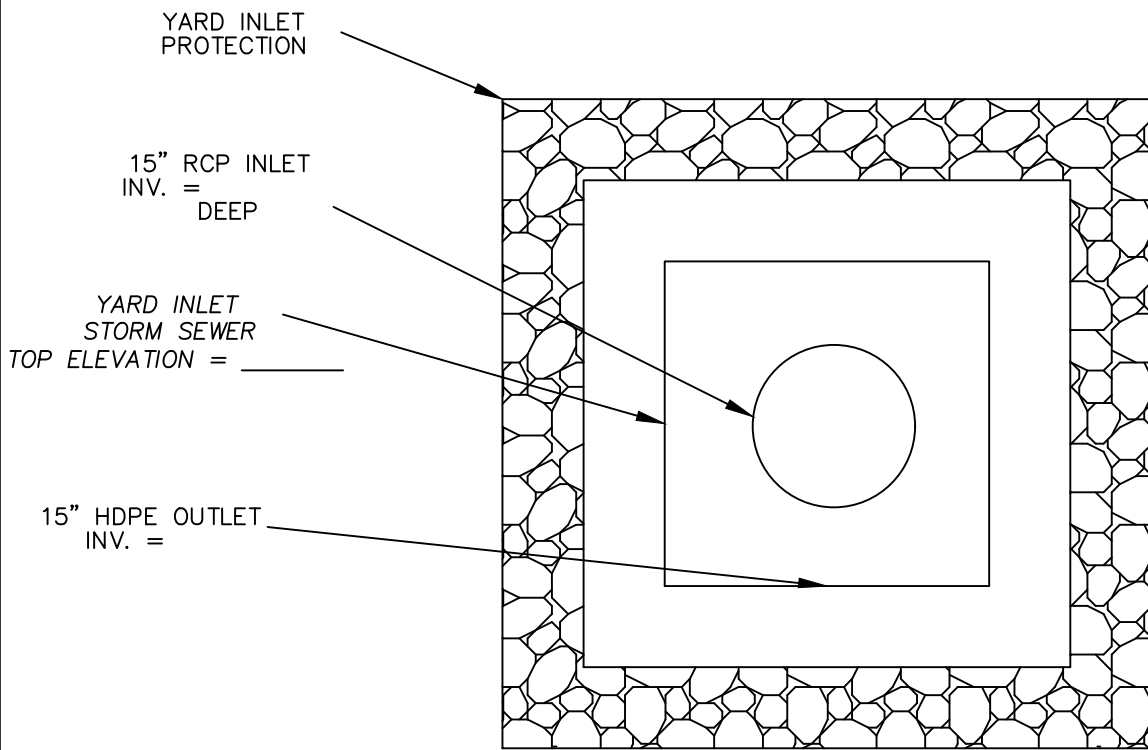

NOT TO SCALE



CITY OF HICKORY

YARD INLET PROTECTION

SHEET 1 OF 1

DATE:
2-1-07

STD. NO.
107

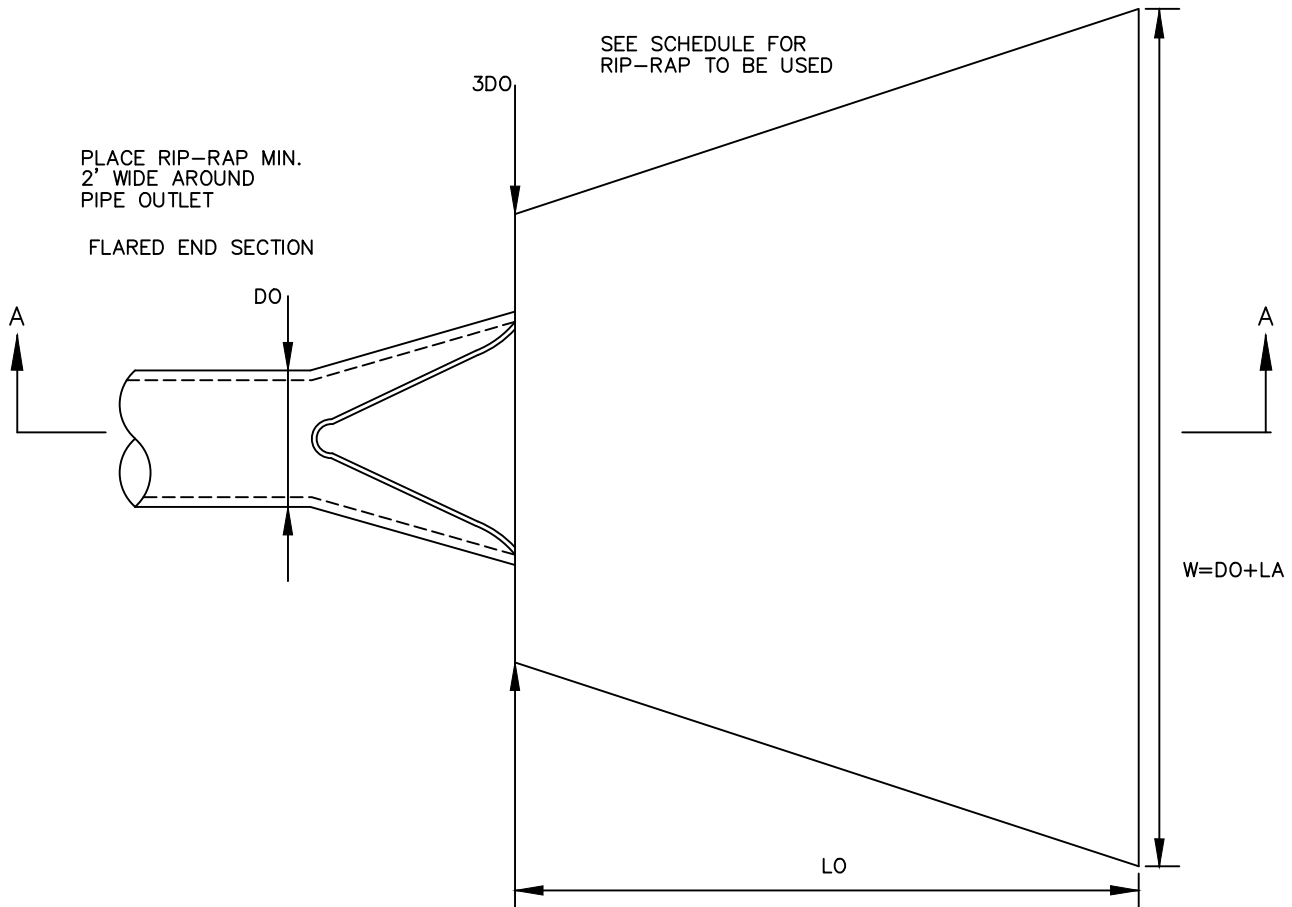

PLAN VIEW

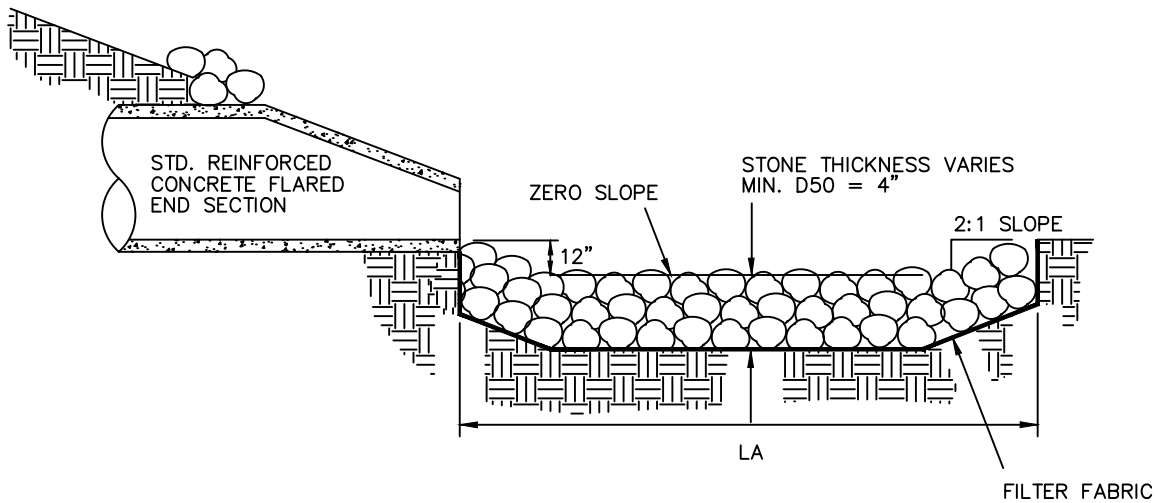

SECTION A-A

SIZE OF DISSIPATOR TO BE DETERMINED AS SHOWN IN SECTION 8.06 OF NCDEQ

NOT TO SCALE



CITY OF HICKORY

RIP-RAP OUTLET PROTECTION

SHEET 1 OF 1

DATE:
2-1-07

STD. NO.
108

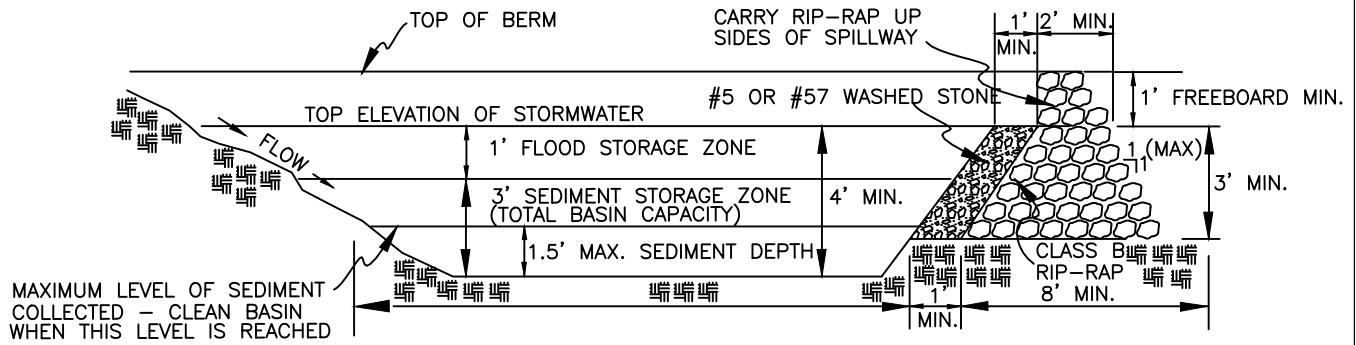

SECTION THRU BASIN & FILTER A-A
GRAVEL & RIP-RAP FILTER BASIN DETAIL

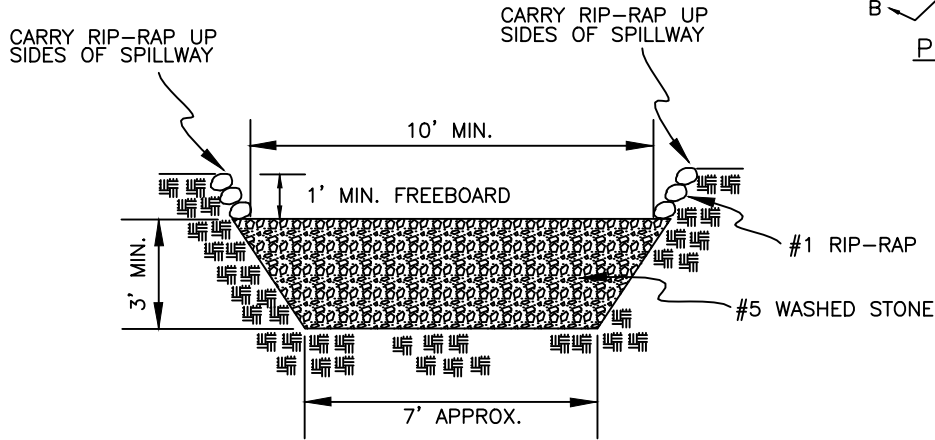
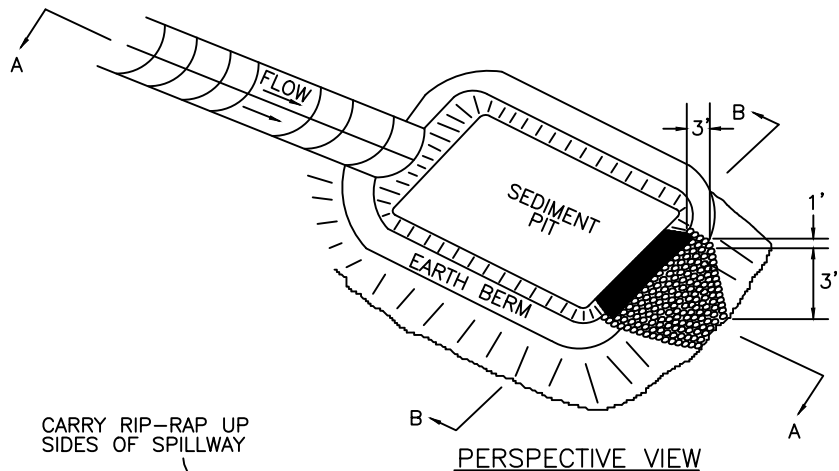

SECTION THRU BASIN & FILTER B-B

NOTE: THIS STRUCTURE MUST BE DESIGNED TO PASS THE 10-YEAR STORM WITHOUT OVERTOPPING THE EARTH BERM.

NOT TO SCALE



CITY OF HICKORY

TEMPORARY SEDIMENT TRAP

DATE:
2-1-07

SHEET 1 OF 1
STD. NO.
109

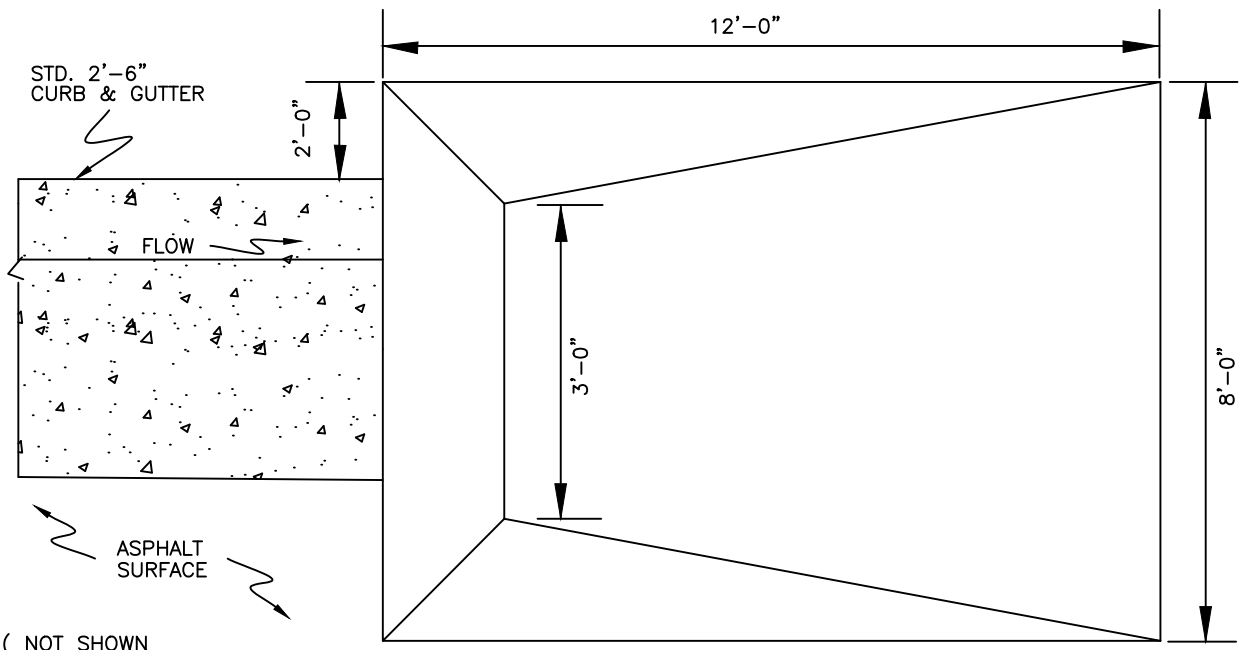

PLAN VIEW

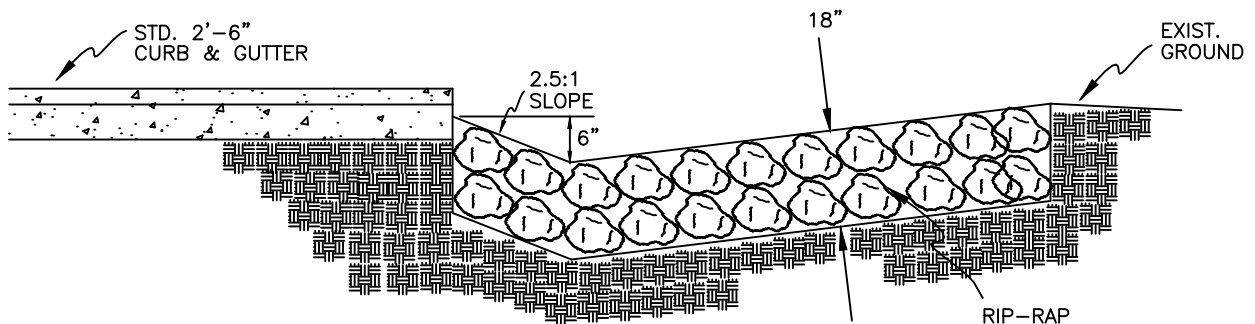

CLASS 1 RIP-RAP TO BE USED.

QUANTITY OF RIP-RAP REQUIRED FOR ONE GUTTER WILL BE 12 S.Y.

SECTION THROUGH DEVICE

NOT TO SCALE



CITY OF HICKORY
 DEAD END STREET
 EROSION CONTROL DEVICE

SHEET 1 OF 1
 DATE:
 2-1-07
 STD. NO.
 111

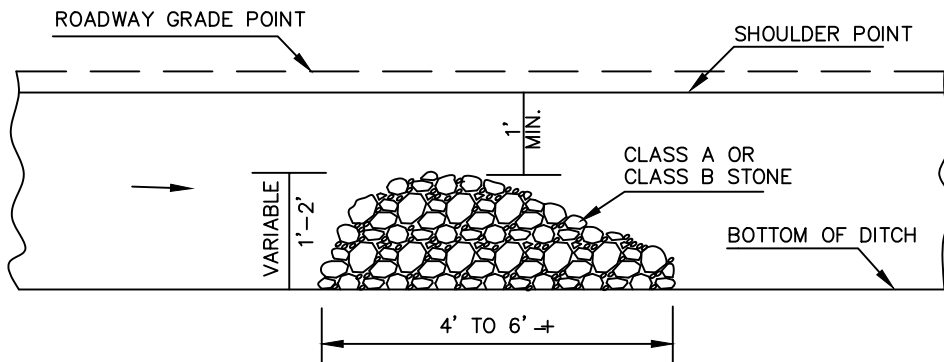
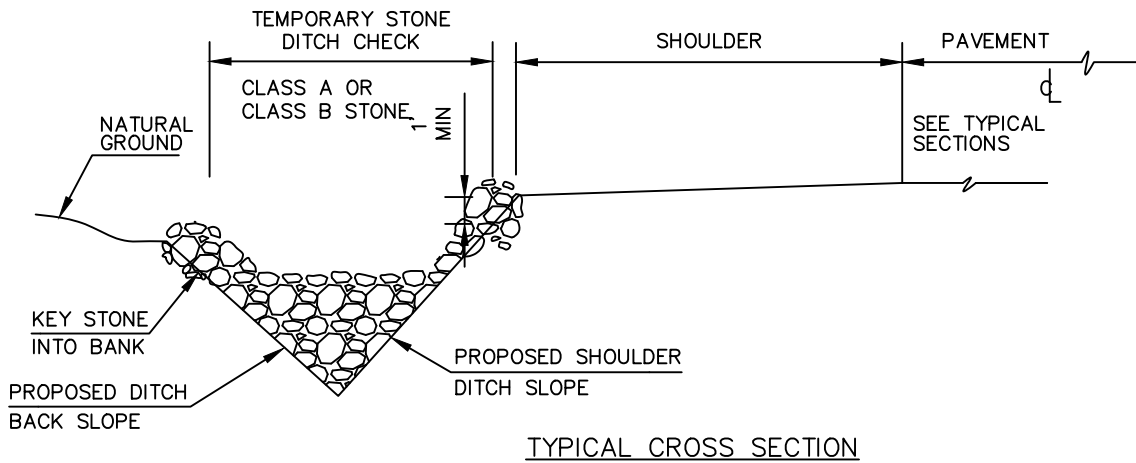
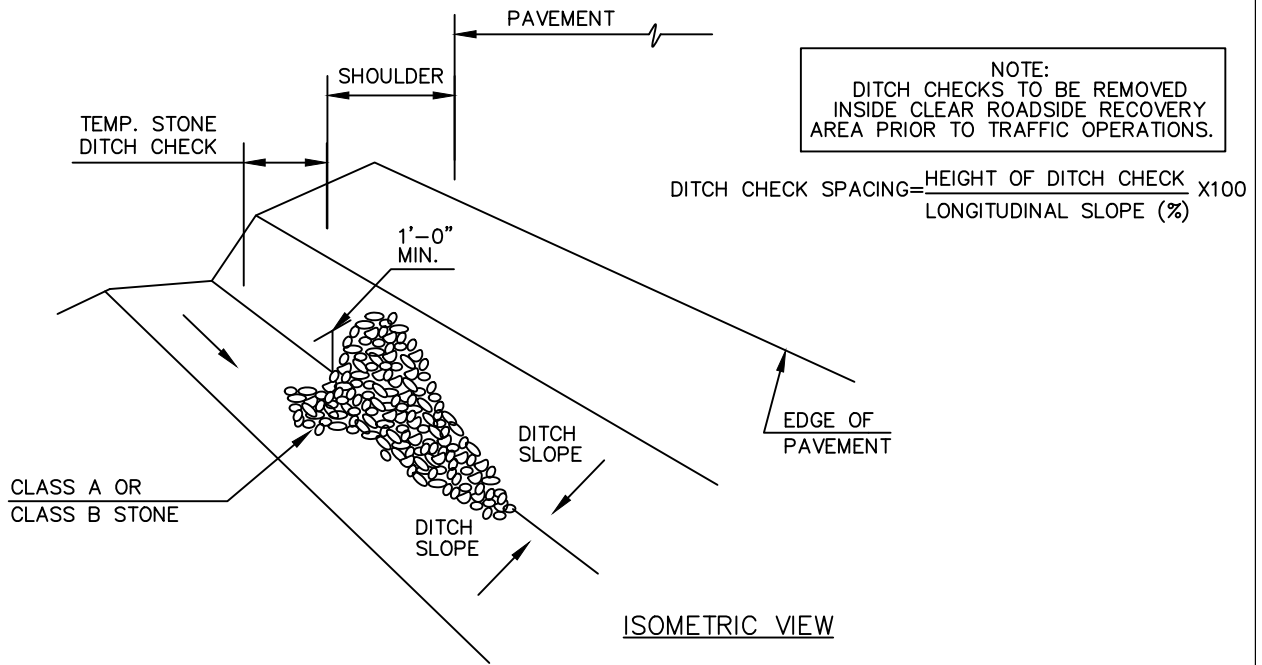

QUANTITY APPROXIMATELY 1 TO 2 TONS STONE

NOT TO SCALE



CITY OF HICKORY
TEMPORARY STONE
DITCH CHECK

SHEET 1 OF 1
DATE:
2-1-07
STD. NO.
112

*NOTE: SEE EROSION CONTROL PLAN FOR PIPE SIZE

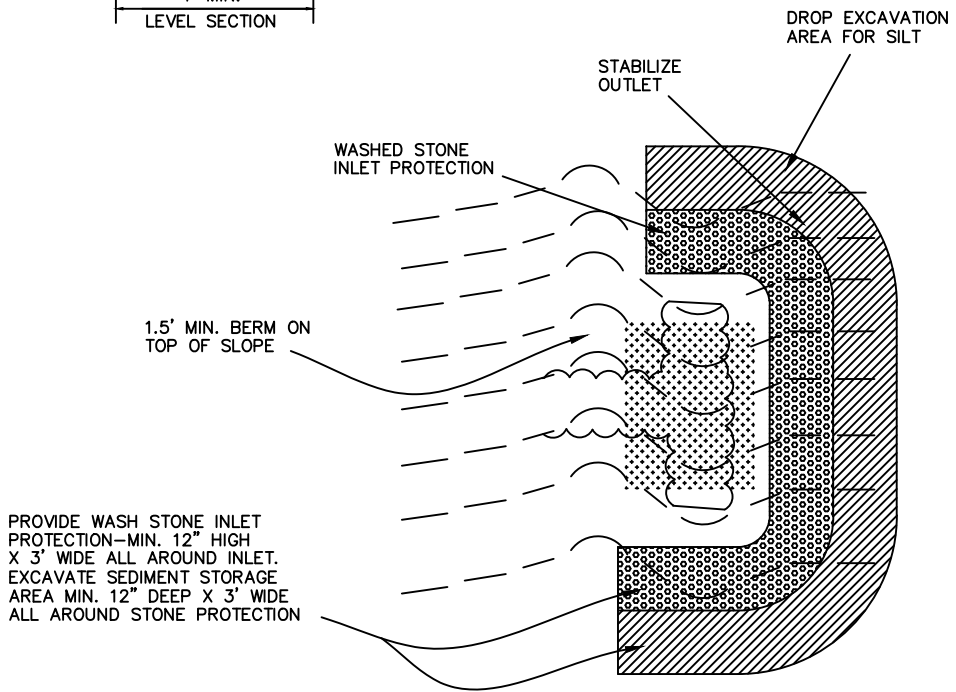
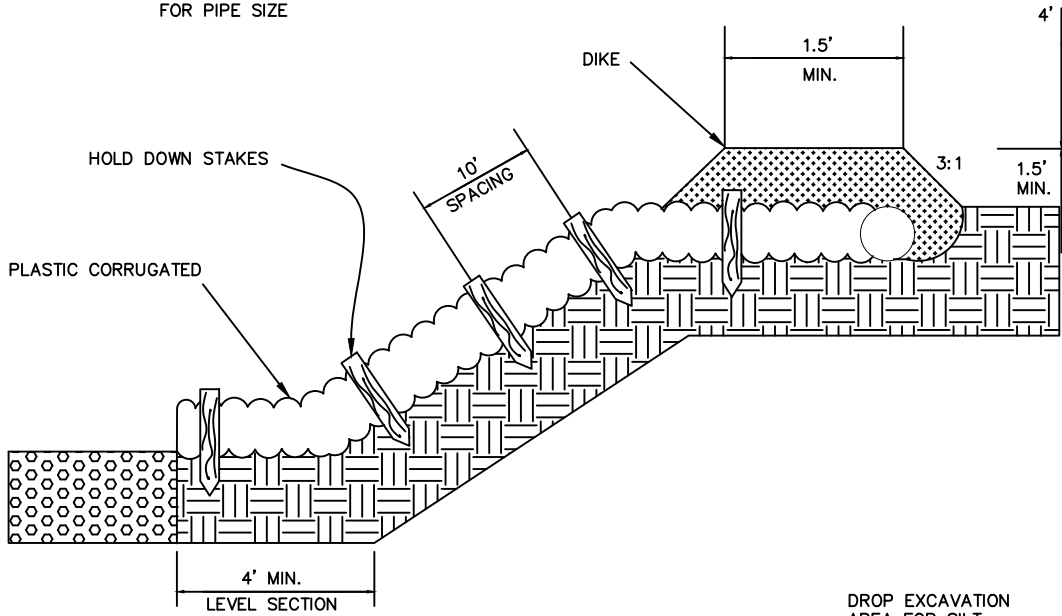

PROVIDE WASH STONE INLET PROTECTION—MIN. 12" HIGH X 3' WIDE ALL AROUND INLET. EXCAVATE SEDIMENT STORAGE AREA MIN. 12" DEEP X 3' WIDE ALL AROUND STONE PROTECTION

PLAN VIEW
STANDARD T-SECTION

NOT TO SCALE



CITY OF HICKORY
TEMPORARY SLOPE
DRAIN DETAIL

SHEET 1 OF 1

DATE:
2-1-07

STD. NO.
113

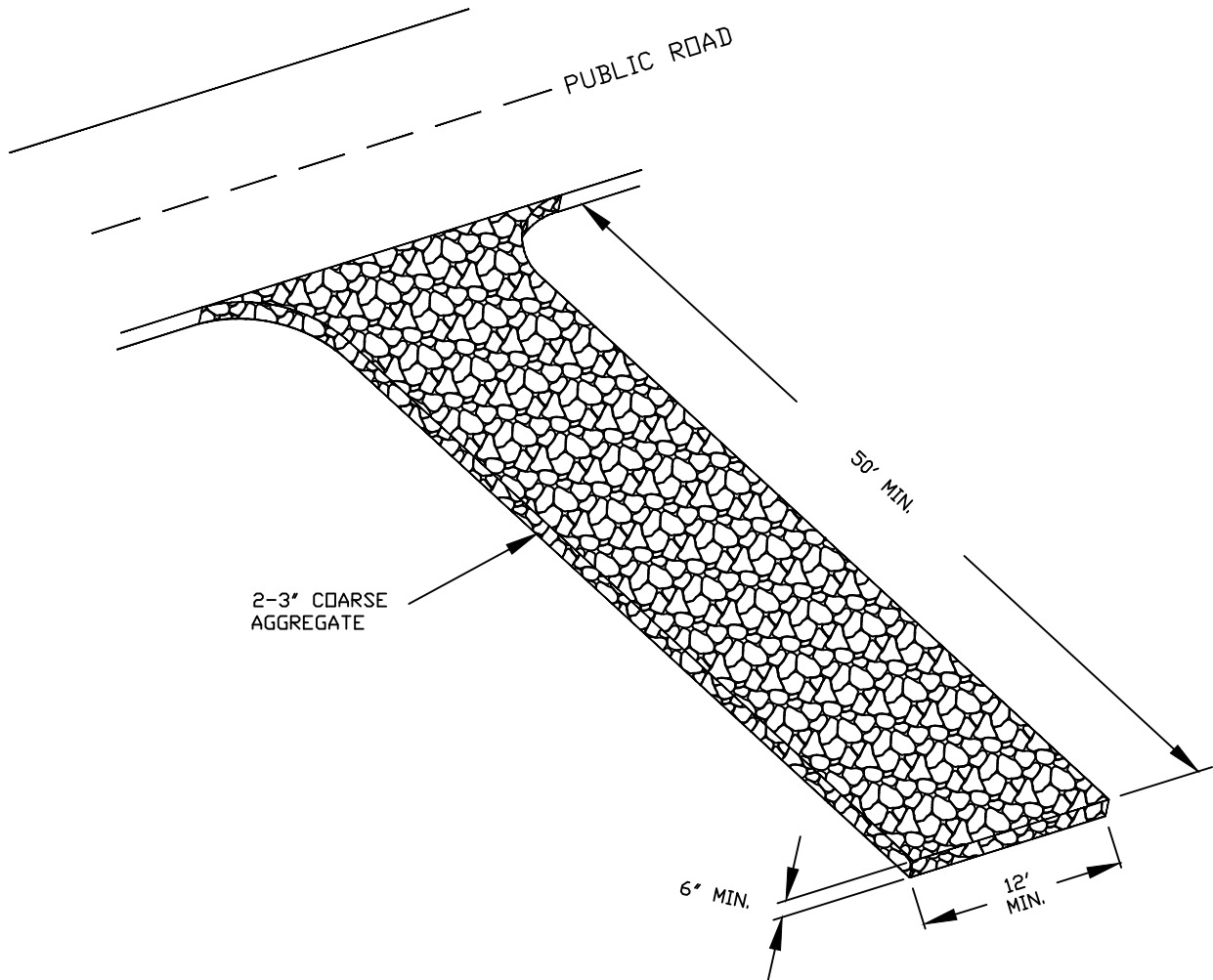

- NOTE:
1. TEMPORARY GRAVEL CONSTRUCTION ENTRANCE SHALL BE MAINTAINED TO REMOVE MUD & SOIL BUILDUP AFTER EACH RAIN EVENT AND AS NEEDED WHEN EFFECTIVENESS IS DIMINISHED
 2. ABC STONE IS NOT ACCEPTABLE

NOT TO SCALE



CITY OF HICKORY

TEMPORARY GRAVEL
CONSTRUCTION ENTRANCE

SHEET 1 OF 1

DATE:
2-1-07

STD. NO.
114